



## Thermal Conductivity Gas-Analyzer



The **CONTHOS 2** state-of-the-art thermal conductivity gas-analyzer is an analytical instrument developed for online industrial use.

Some of the outstanding technical features of LFE's 2nd-generation, microprocessor based gas-analyzer are:

- high-temperature TC-detector (TCD), temperature controlled from 50°C to max. 180°C continuous operating temperature.
- high corrosion-resistance of components in contact with medium
  - unusually quick response time: typically  $\leq 2$ s
  - response highly independent of the gas flow
  - unusually high long-term response stability
  - intuitive user-interface based on NAMUR<sup>1</sup> –recommendations
  - automatic self-diagnosis
  - optional dynamic interference correction of up to 3 gases

The technical features of the unique CONTHOS 2 gas analyzer open up new areas of application for the thermal-conductivity principle, as well as help to eliminate weak points in present analysis problems.

Choosing the TCD-operating-temperature above that of the dew-point of the sample-gas can, in conjunction with external and internal heated gas lines (field housing only), alleviate the need for a sample-gas cooler.

First developed in 1979 the LFE - **CONTHOS** gas analyzer has proven itself in many years of continuous operation in such fields as:

- in the iron and steel industry
- in corrosive process gases in the chemical industry
- in all of the "classical" applications of the TCD-principle

### Model variations and options

- 19"-rack housing (protective class IP40) or field-housing (protective class IP65)
- Exp ATEX-version in conjunction with purge-gas pressure monitor
- 2<sup>nd</sup> & 3<sup>rd</sup> switched ranges: independently configurable, suppressed & non-suppressed
- Interference correction in conjunction with external, selective gas analyzers for multiple gas constituents
- Digital I/O-board for external range switching, threshold contacts, etc.
- RS-485 interface with Modbus RTU protocol
- Heated gas lines within analyzer housing (max. 140°C; field housing only)



<sup>1</sup> NAMUR commission: Standardization commission for measuring and control technology in the German chemical industry (sub-committee for operability of microprocessor-controlled process analytical- instrumentation)

## Detector Design

In conventional gas analyzers utilizing the principle of thermal conductivity a heatable object is suspended in a volume containing the sample gas. Electrical energy passed through the object results in the object heating up and attaining an equilibrium temperature which is primarily dependent upon the thermal conduction properties of the surrounding gas. This temperature is normally measured directly as a change in the electrical resistance of the heated object itself.

LFE's unique principle modifies this "classical" method by spatially and electrically decoupling the heated element from the temperature sensing element. The specially designed geometry of the TCD-cell in conjunction with the decoupling effectively suppresses undesired competing thermal effects (i.e. free and forced convectional effects). The result is an instrument whose quick, stable response requires no compromise between gas flow and response time.

The micro-miniaturized TCD-cell ( $V = 1\text{mm}^3$ ) is constructed of the highly corrosion-resistant materials aluminum-oxide ( $\text{Al}_2\text{O}_3$ ), glass and platinum.

The detector-assembly is mounted in an insulated, temperature regulated aluminum block and can be operated at continuous temperatures up to  $180^\circ\text{C}$ .

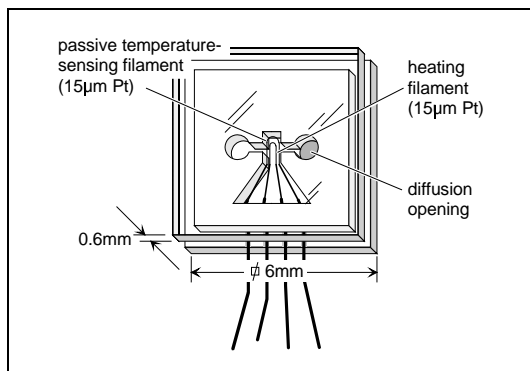
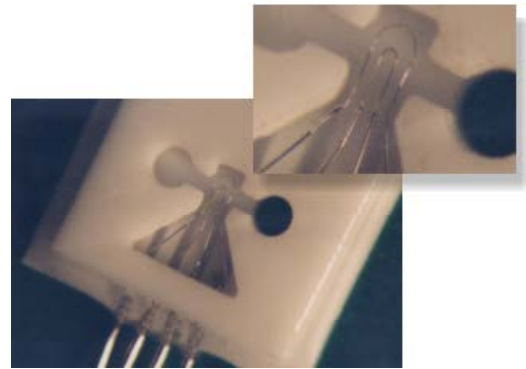

- The heating filament and temperature sensing filament are spatially and electronically decoupled.
- Miniaturization of measuring elements and cells (quick response)
- Highly corrosion resistant (materials used: aluminum-oxide ( $\text{Al}_2\text{O}_3$ ), glass and Pt)

## Technical Data

### General technical data

	19"-rack housing	Field-housing	EExp-ATEX instrument
Housing	3HE/ 84TE housing for mounting in 19" cabinet	purgable steel housing for wall mounting; with separate compartments for the electronic and analytical components	housing based upon standard field housing instrument plus additional components for inert gas purging
Protection Class	IP40	IP65	
Dimensions (H x W x D)	132 x 483 x 360 mm (total depth including handles and gas connectors: 430mm)	565 x 495 x 265 mm	565 x 585 x 265 mm
Power requirements	100-240VAC (48-62Hz) 150VA max.	100-240VAC (48-62Hz) 150VA max.	100-120VAC (48-62Hz) or 220-240VAC (48-62Hz) 150VA max.
Sample gas connectors	<u>Standard</u> : Swagelock (SS) connectors for tubing (o.d. 6mm) <u>Optional</u> : 1/4"-NPT (female connectors; SS)	<u>Standard</u> : Swagelock (SS) connectors for tubing (o.d. 6mm)	The flame arrestors included as part of the package have adapters for 6mm connectors on the analyzer side. The customer side is for NPT 1/4" – female connectors.

### LFE GmbH & Co.KG

Am Germanenring 54 D-63486 Bruchköbel/Germany  
Tel. : (+49) 6181-495302 Fax : (+49) 6181-493807  
Internet: www.LFE.de

## Data display, inputs and outputs

Read-out	LC-display (40 characters x 16 lines) + bar graph User interface based on NAMUR recommendation Language: switchable btwn. English & German
Analog Signal output	Isolated analog output (linearized): $R_{Load} = 600\Omega$ max. Output level configurable: 0-20 mA, 4-20mA, 4-20mA (with superimposed instrument status according to NAMUR recommendation NE43) as well as a set signal levels (0mA, 4mA, 10mA, 12mA & 20 mA)
Digital Outputs (Instrument Status)	Plain text description on the LC-display as well as digital status output via floating contacts (28V max.; 350mA max.) : INSTRUMENT FAULT   MAINTENANCE REQUIRED   MAINTENANCE
Analog Inputs (optional)	3 isolated, configurable analog inputs for interference correction. 0 – 20mA or 4 – 20mA ( $R_i = 50\Omega$ )
Digital I/O (optional)	Digital inputs: 7 configurable inputs (6 – 24VDC; 10mA max.) Digital outputs: 7 configurable outputs (relay contacts 28V max.; 350mA max.)

## Materials in contact with sample gas

TC-Detector	$Al_2O_3$ -ceramic and sapphire, Pt and glass (high corrosion- and temperature-resistance) (Pt-measuring filaments optionally available with $SiO_x$ -coating <sup>2</sup> )
Sample Gas Lines	standard: PTFE (optional: stainless steel gas lines)
Sample-gas connectors	standard : stainless steel optional : for applications with higher requirements on corrosion resistance the following can be provided: PVDF-connectors for PTFE tubing or alternatively: PTFE-tubing (strain released) connected directly to TC-detector

Analytical-/ Operational Data<sup>3</sup> (complete instrument)

Measuring Principle	Thermal conductivity (TCD)
Measured quantity	Concentration of a particular gas component in binary and quasi-binary mixtures. In many applications involving multi-component gases the inherent non-selectivity of the thermal conductivity principle can be minimized using interference correction techniques. Physical interference reduction is possible with certain applications due to the wide temperature range of the CONTHOS' TC-detector.
Measuring Ranges	Optionally up to 3 independently configurable, switchable ranges. The fundamental response of each range is factory linearized. Suppressed ranges within the corresponding fundamental range can be easily configured. Range switching is accomplished manually, automatically and/or externally (option). lowest range: 0 - 0.5% $H_2$ in $N_2$ (or equivalent $\Delta\lambda$ )   largest range: 0 - 100% $H_2$
Response Time ( $\tau_{90}$ )	typically approx. 2 sec. (dependent upon gas flow and analyzer configuration)
Gas sample	Sample gas must be pre-filtered to remove particles. Dew-point low enough so as to prevent condensation in the gas lines under ambient temperature conditions. The standard operating temperature of the CONTHOS TCD-detector-assembly itself is 70°C (depending on the application the operating temperature is factory set to btwn. 50° - 180°C).
Precision	$\leq 0.5\%$ F.S.O. (typically better than $\pm 0.2\%$ F.S.O.)
Accuracy	better than $\pm 0.5\%$ F.S.O. (typically better than $\pm 0.3\%$ F.S.O.)
Dynamic interference correction <sup>4</sup>	in conjunction with optional 3-channel analog input board (input levels: 0-20mA or 4-20mA) Each channel can be individually configured for the correction of a particular gas constituent.

Unless otherwise specified the CONTHOS gas analyzer is neither ex-proof nor intrinsically safe in terms of explosion protection.

The **CONTHOS** may not be employed for the analysis of ignitable gas-mixtures. The customer must ensure compliance with applicable regulations when using the analyzer with inflammable or toxic gases or when installing within explosion endangered environments.

Specifications subject to change without notice

- <sup>2</sup> Required, for example, for  $H_2$  measuring applications in which oxygen is present.  
Ensures response stability by eliminating potential catalytic-thermal effects on the Platinum measuring filaments.
- <sup>3</sup> The stability data is valid for analyzer operation with pure bottled gases. Deviations from the above data can occur in conjunction with process gases depending upon the gas quality and the degree of gas handling.
- <sup>4</sup> Interference correction: The basic requirement for the electronic interference correction of the CONTHOS-response is the presence of an external signal, proportional to the particular gas component to be corrected for. The input signal level should be either 0 - 20mA or 4 - 20mA. The processing of analyzer ranges with a suppressed zero is not possible.

## LFE GmbH &amp; Co.KG

Am Germanenring 54 D-63486 Bruchköbel/Germany  
Tel. : (+49) 6181-495302 Fax : (+49) 6181-493807  
Internet: www.LFE.de